

MIN 86 MAX 131

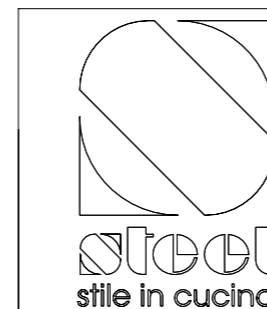
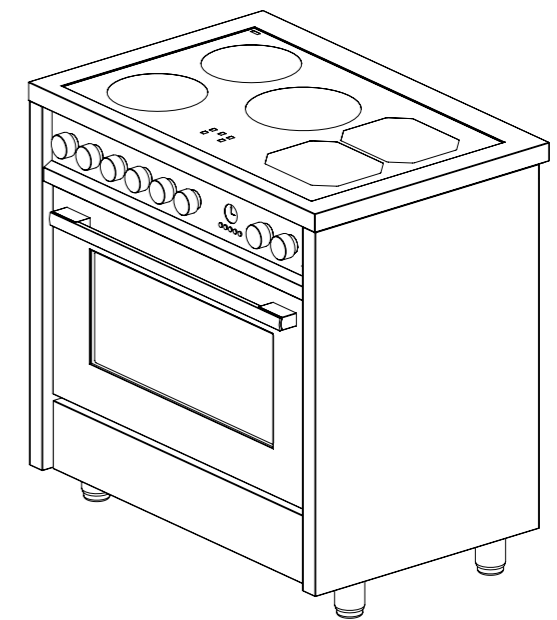

DESCRIZIONE / DESCRIPTION		CODICE/CODE		REV.	NR.PZ.
Cucina Adagio 09F-5FI		-		-	-
		MATERIALE/MATERIAL			
RIF. CLIENTE/CUSTOMER'S RE.		RIF. FORNITORE/SUPPLIER'S RE.		TRATTAMENTO/PROCESS	
-		-		-	
DISEGNATORE/EDITOR		APPROV.		DATA/DATE	SCALA
Davide		-		11/10/2019	1:10
				MASSA/MASS kg	-
<small>Proprietà della STEEL S.p.A. CARPI (MO). Senza l'ormale autorizzazione scritta della stessa il presente disegno non potrà essere utilizzato per la costruzione dell'oggetto rappresentato né venire divulgato o riprodotto, la proprietaria tutela i propri diritti a rigore di legge.</small>					